



















AS Schöler + Bolte

Product overview 05

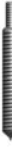
 <p>DRH</p>	 <p>DRP</p>	 <p>DRS</p>	 <p>DRT</p>
 <p>FFH</p>	 <p>FFS</p>	 <p>FFT</p>	 <p>FFD</p>
 <p>IPH</p>	 <p>IPS</p>	 <p>IPT</p>	 <p>TPH</p>
 <p>TPS</p>	 <p>TPT</p>	 <p>DRS-MS</p>	 <p>DRS-M6</p>
 <p>MD</p>	 <p>PD</p>	 <p>RD</p>	 <p>UDB</p>

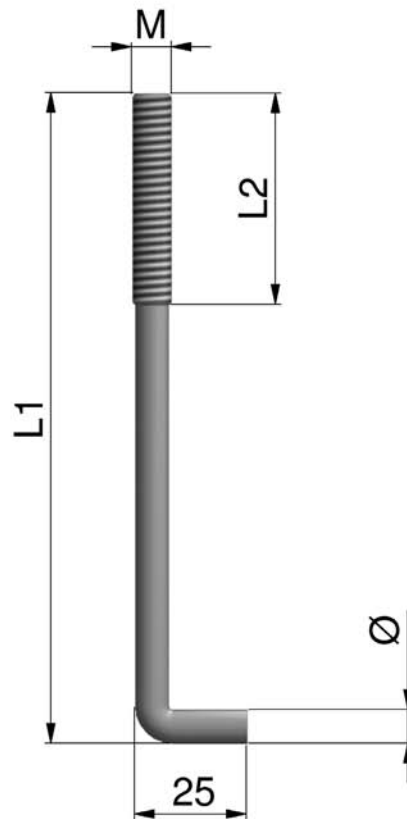

DRH-M6-250-50-1.4841

Stud type
Thread diameter M
Stud length L1
Thread length L2
Alloy type

07 Threaded washer/ Clip/ Square nuts

AS Schöler + Bolte

Refractory Anchoring Systems

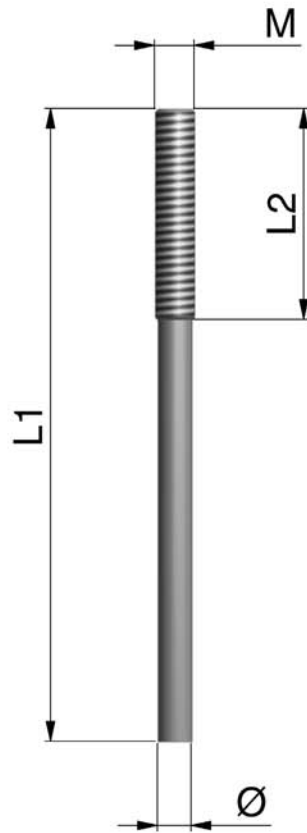

DRP-M6-250-50-1.4841

Stud type

Thread diameter M

Stud length L1

Thread length L2

Alloy type

07 Threaded washer/ Clip/ Square nuts

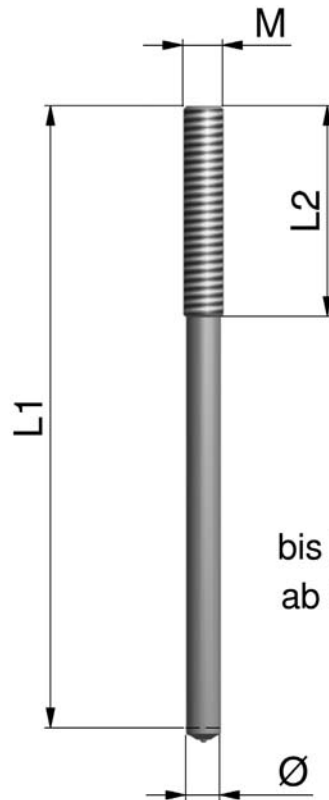

bis M6 ohne Aluminiumkugel
ab M8 mit Aluminiumkugel

DRS-M6-250-50-1.4841

Stud type
Thread diameter M
Stud length L1
Thread length L2
Alloy type

07 Threaded washer/ Clip/ Square nuts

09 Ferrules

10 Stud welding unit/ Welding gun

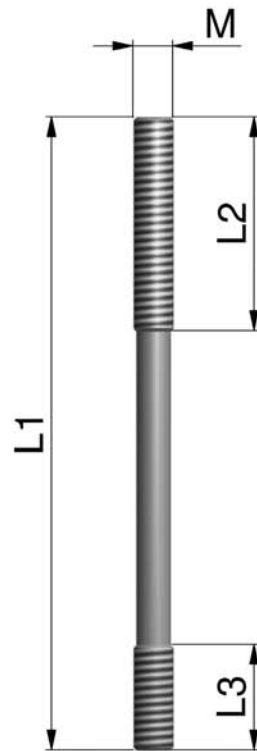

DRT-M6-250-50-25-1.4841

Stud type
Thread diameter M
Stud length L1
Thread length L2
Thread length L3
Alloy type

07 Threaded washer/ Clip/ Tapped stud/ Square nuts

AS Schöler + Bolte

Refractory Anchoring Systems

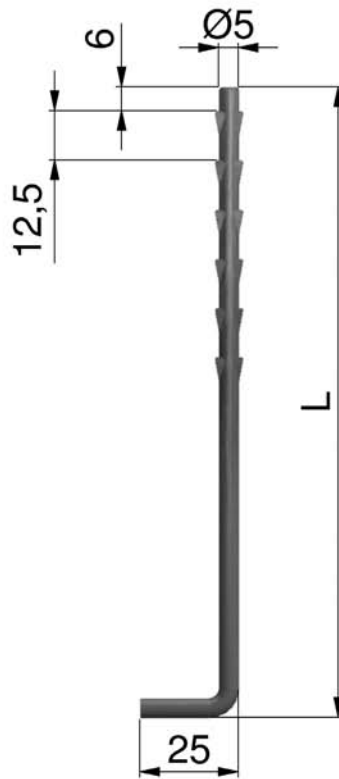

FFH-150-1.4841

Stud type
Stud length L
Alloy type

07 Clip

AS Schöler + Bolte

Refractory Anchoring Systems

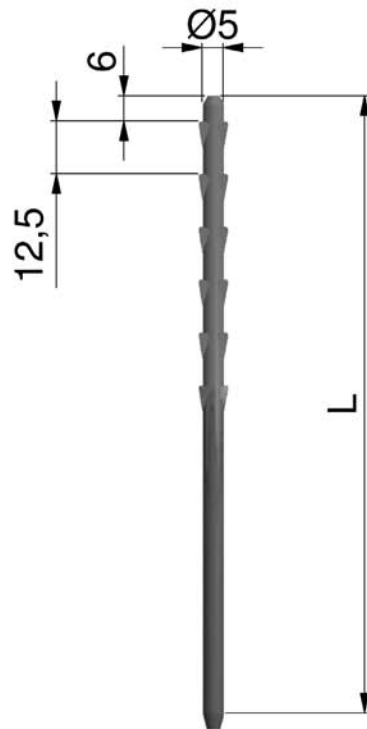

FFS-150-1.4841

Stud type
Stud length L
Alloy type

07 Clip

09 Ferrules

10 Stud welding unit/ Welding gun

AS Schöler + Bolte

Refractory Anchoring Systems

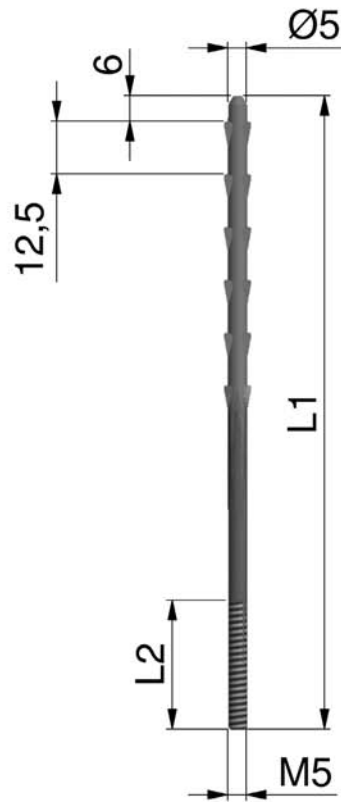

FFT-150-30-M5-1.4841

Stud type
Stud length L1
Thread length L2
Thread diameter M
Alloy type

07 Clip/ Tapped stud

AS Schöler + Bolte

Refractory Anchoring Systems

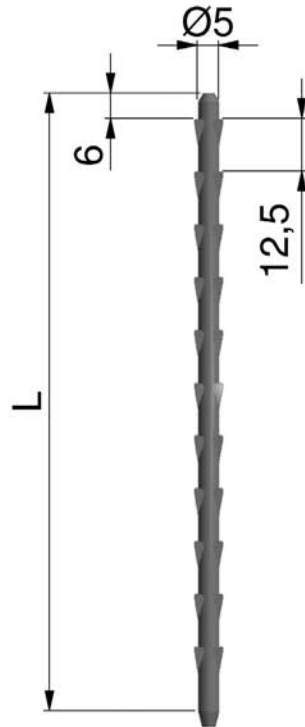

FFD-150-1.4841

Stud type
Stud length L1
Alloy type

07 Clip

09 Ferrules

10 Stud welding unit/ Welding gun

AS Schöler + Bolte

Refractory Anchoring Systems

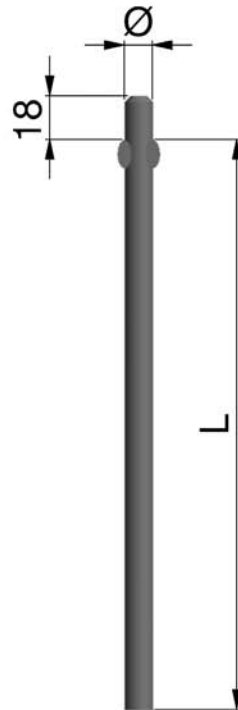

IPH-10-200-1.4841

Stud type
Diameter \varnothing
Stud length L
Alloy type

07 Washer

AS Schöler + Bolte

Refractory Anchoring Systems

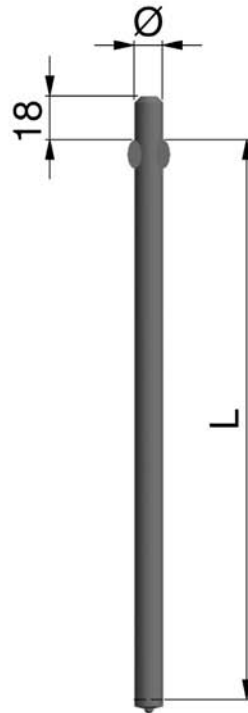

IPS-10-200-1.4841

Stud type
Diameter \varnothing
Stud length L
Alloy type

07 Washer

09 Ferrules

10 Stud welding unit/ Welding gun

AS Schöler + Bolte

Refractory Anchoring Systems



IPT-10-200-30-M10-1.4841

Stud type
Diameter Ø
Stud length L1
Thread length L2
Thread diameter M
Alloy type

07 Washer/ Tapped stud

AS Schöler + Bolte

Refractory Anchoring Systems

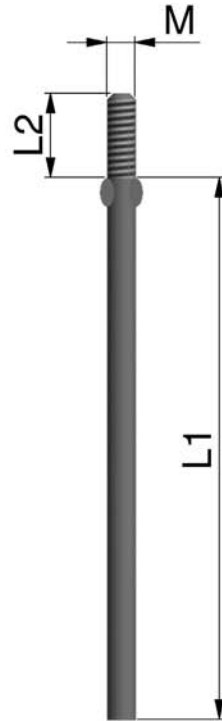

TPH-200-20-M10-1.4841

Stud type

Stud length L1

Thread length L2

Thread diameter M

Alloy type

07 Washer/ Square nuts/ Threaded washer

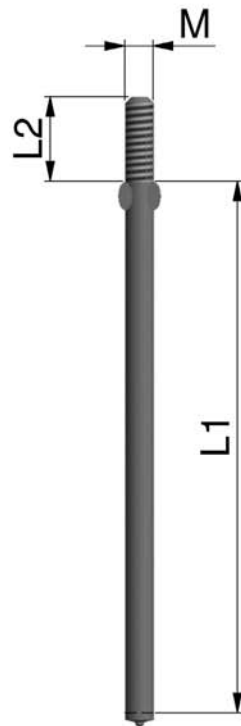

TPS-200-20-M10-1.4841

Stud type
 Stud length L1
 Thread length L2
 Thread diameter M
 Alloy type

07 Washer/ Square nuts/ Threaded washer

09 Ferrules

10 Stud welding unit/ Welding gun

AS Schöler + Bolte

Refractory Anchoring Systems

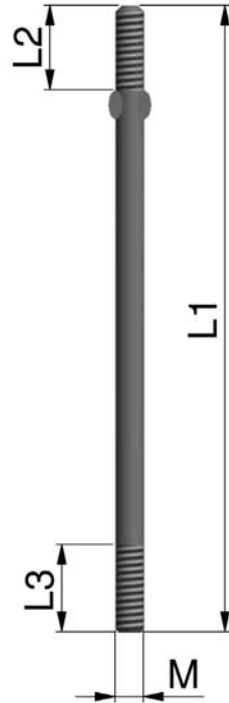

TPT-200-30-20-M10-1.4841

Stud type
Stud length L1
Thread length L2
Thread length L3
Thread diameter M
Alloy type

07 Washer/ Tapped stud/ Square nuts/ Threaded washer

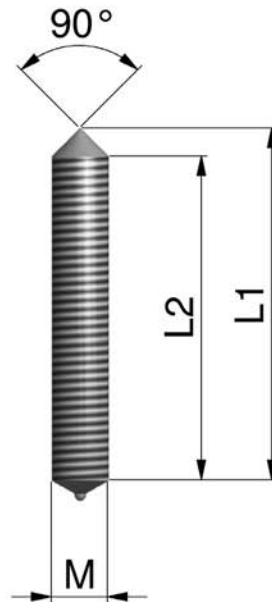

DRS-M8-25-MS-1.4841

Stud type

Thread diameter M

Stud length L1

Alloy type

07 Washer/ Square nuts

09 Ferrules

10 Stud welding unit/ Welding gun

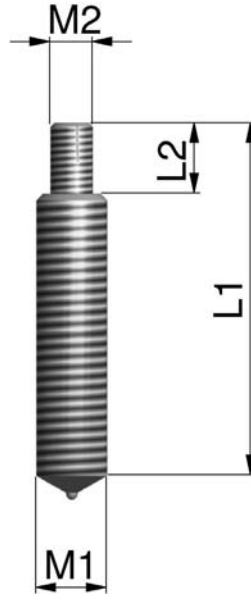

DRS-M10-50-M6-10-1.4841

Stud type
Thread diameter M1
Stud length L1
Thread diameter M2
Thread length L2
Alloy type

07 Washer/ Square nuts

09 Ferrules

10 Stud welding unit/ Welding gun

AS Schöler + Bolte

Refractory Anchoring Systems

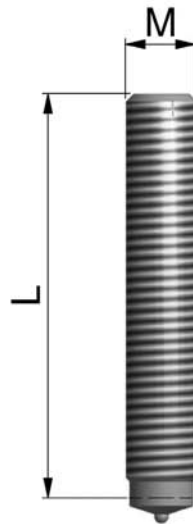

MD-M10-60-1.4301

Stud type

Thread diameter M

Stud length L

Alloy type

07 Washer/ Square nuts

09 Ferrules

10 Stud welding unit/ Welding gun

AS Schöler + Bolte

Refractory Anchoring Systems

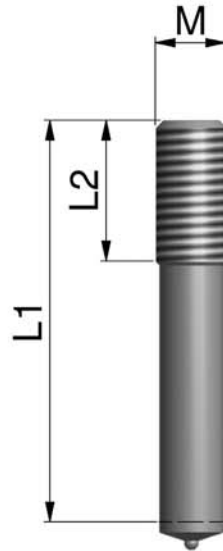

PD-M10-200-20-1.4301

Stud type

Thread diameter M

Stud length L1

Thread length L2

Alloy type

07 Washer/ Square nuts

09 Ferrules

10 Stud welding unit/ Welding gun

AS Schöler + Bolte

Refractory Anchoring Systems

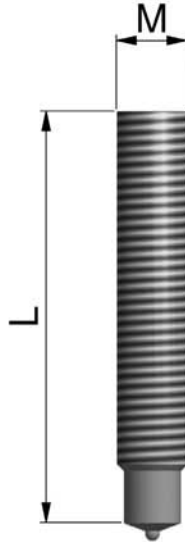

RD-M10-30-1.4301

Stud type

Thread diameter M

Stud length L

Alloy type

07 Washer/ Square nuts

09 Ferrules

10 Stud welding unit/ Welding gun

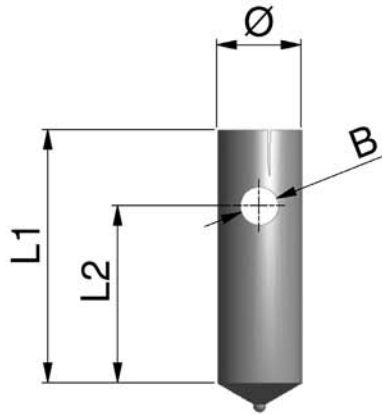

UDB-10-30-20-4,5-1.4841

Stud type
Stud diameter \varnothing
Stud length $L1$
Length $L2$
Drilled hole B
Alloy type

09 Ferrules

10 Stud welding unit/ Welding gun